

HYDAC

INTERNATIONAL



**All-Round Protection
From the Refinery
to the Engine:
HYDAC DieselProtection**

Diesel filtration + Dewatering + Fuel Condition Monitoring





Emissions directives are raising the standards for diesel fuels. As a consequence, suppliers must guarantee that there is less contamination and lower water content in their fuels. The increasing percentage of biodiesel has the additional effect that existing systems must be retrofitted with **diesel conditioning systems**.

In order to meet the requirements, it is not sufficient to condition the diesel just prior to usage in the machine. The fuel must be filtered and dewatered at every stage of the transport chain – **from production in the refinery to the end user**. To comply with the high quality requirements it is essential to monitor particle contamination and water content.

The HYDAC product range includes **the housings, fluid conditioning units** and **sensors** necessary to do this. For every step of the process – from production to consumption – HYDAC provides specific products for optimum fluid monitoring and conditioning.

In addition to the on-board products for smaller diesel quantities on machines, equipment is also available for larger flows. This is used during transport between different storage depots, on fuel stations and when transferring to the engine.

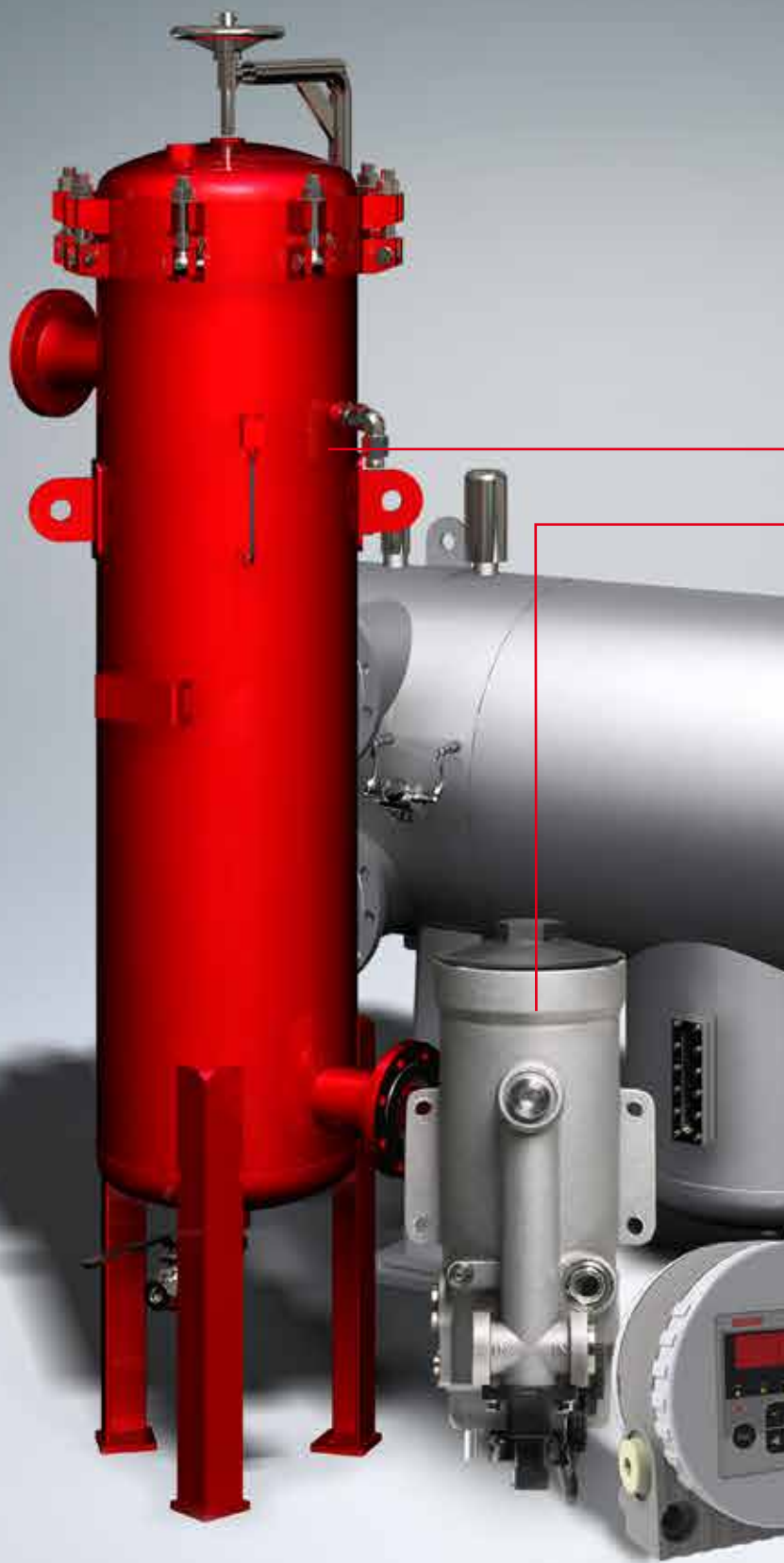

For you, filtration, dewatering and fuel condition monitoring means: Protection from breakdowns, stoppages and expensive service interventions. Everywhere. FROM ONE SUPPLIER.

Protection by Filtration

Protection by Dewatering

Protection by Fuel Condition Monitoring

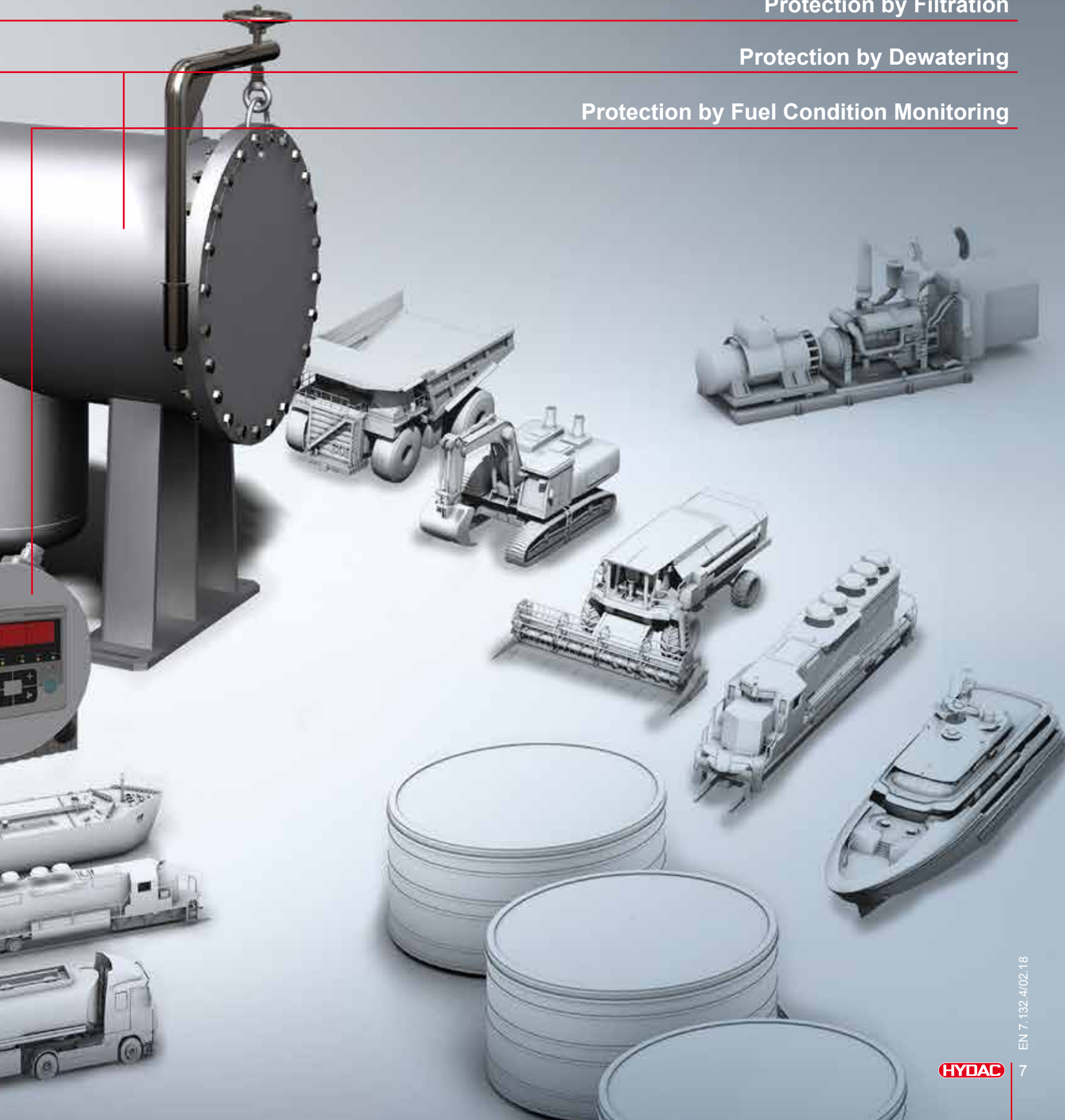

The HYDAC concept for optimum fluid cleaning:



Particle elimination from Diesel

Filtration for particle separation

The function of the **LowViscosity Housing Filter LVH-F** is to separate particle contamination from diesel. Its design makes it ideally suited to removing large quantities of contamination reliably in a single pass, thereby guaranteeing the required cleanliness. If in addition to filtration, dewatering of the diesel is also required, the filters can be installed as a pre-filter stage and combined with the **LowViscosity Housing Coalescer LVH-C** dewatering unit.



The filter housings which HYDAC uses in diesel filtration are designed according to **ASME Section VIII Div. 1 or AD 2000**. Both vertical and horizontal housing configurations are available and since these can process up to several thousand litres per minute, simple installation in both the refinery and bulk storage tanks is possible.



Dewatering of Diesel

Dewatering by coalescence

Diesel is dewatered in the **LowViscosity Housing Coalescer LVH-C**. The elements used here are not consumable items as is usually the case in filter elements which absorb free water. During coalescence, smaller water droplets combine into larger ones and fall to the bottom of the coalescer housing. Any ultra fine water droplets remaining in the diesel are removed from the diesel flow in a secondary filtration stage using separation elements and also settle in the housing. The separated water collects in the base of the housing and can be discharged by opening a valve.

Thanks to the **LowViscosity Housing Coalescer LVH-C** from HYDAC, large diesel volumes can thus be dewatered efficiently while also ensuring responsible use of resources.

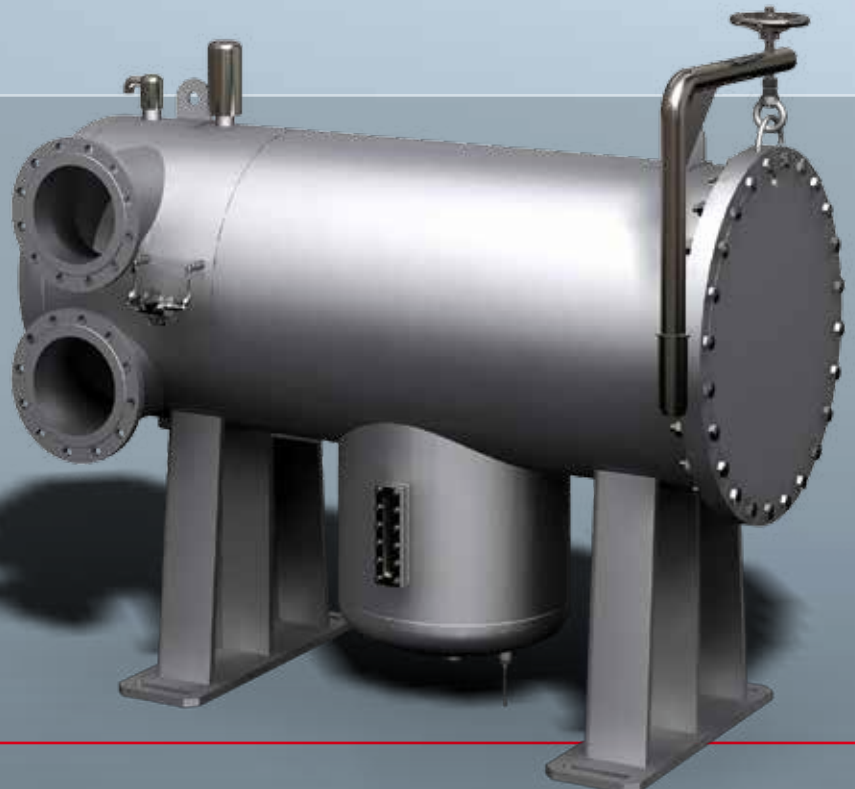

HYDAC ALL-ROUND PROTECTION for Diesel: from manufacture to consumption

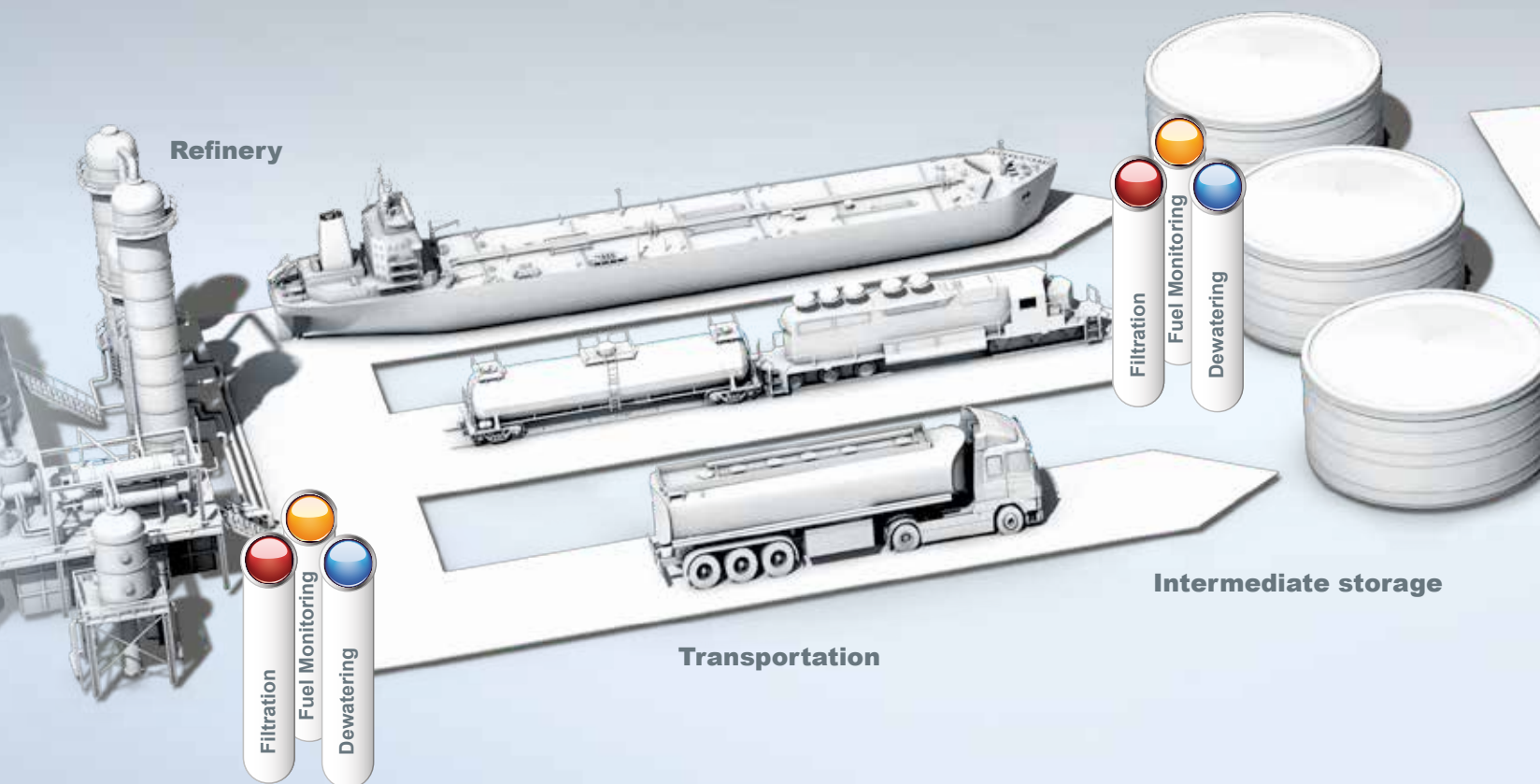

Filter Elements +



Dewatering Elements

The **Optimicron Diesel filter elements** specially developed for the filtration of diesel are characterised by a very high contamination retention capacity and simultaneously low pressure drop. This results in a long service life for the elements.



The use of state-of-the-art materials guarantees excellent separation rates even in a single pass and this continues over the entire lifetime of the filter element.

The **Optimicron Diesel elements** for two-stage dewatering use materials specifically designed for coalescing and for separating water from diesel. They enable secure and efficient dewatering even when the water content of the diesel is low.

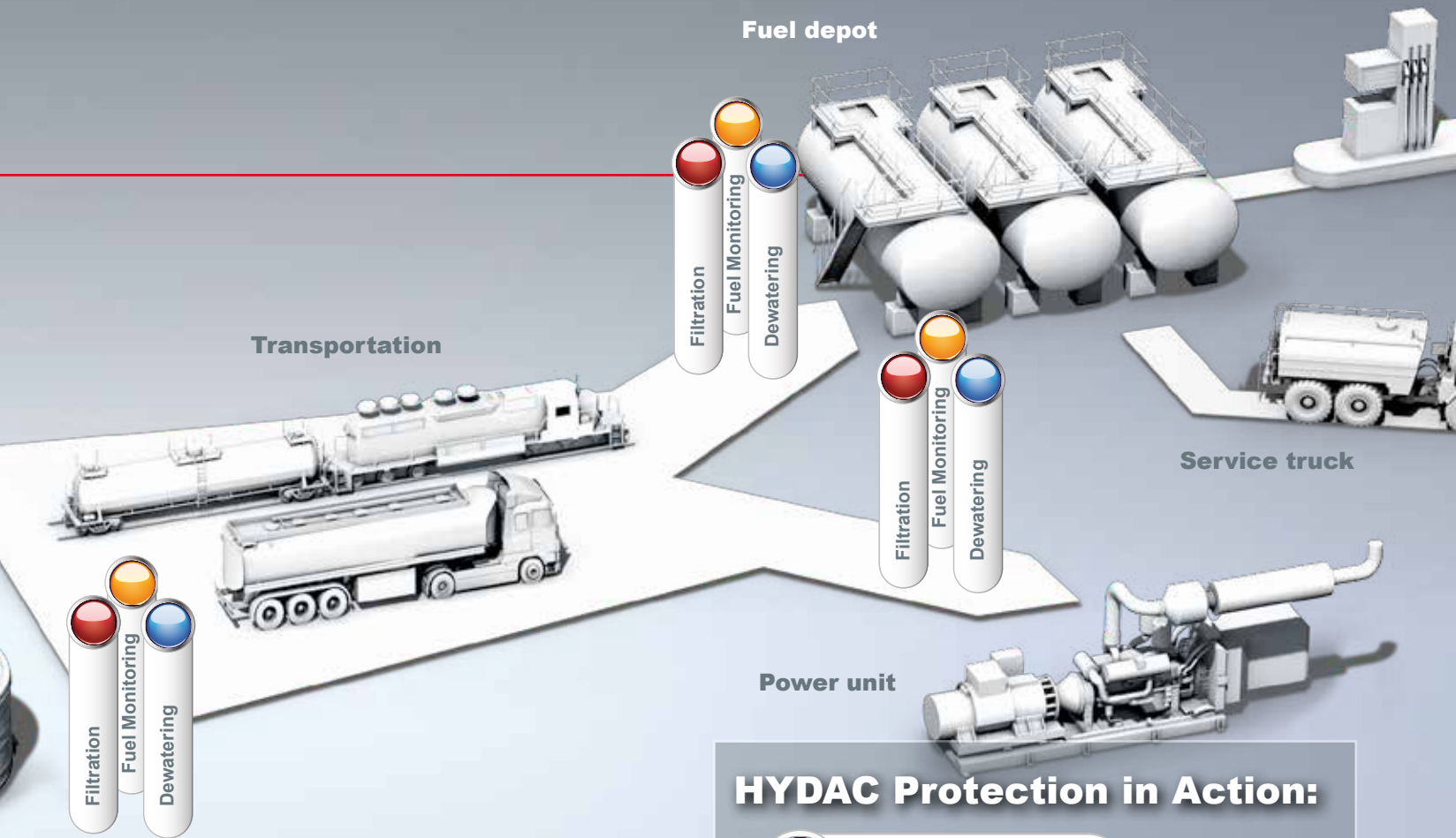



HYDAC Protection in Action:

-  Filtration
-  Dewatering
-  Fuel Monitoring



On Board-Dewatering

In order to guarantee trouble-free operation of commercial vehicles exposed to the harshest operating conditions all over the world, and in order to protect both the engine and the whole drive train from damage, optimum conditioning of the diesel fuel is particularly important. HYDAC offers a comprehensive range of products for mobile diesel filtration which protects the vehicle manufacturer and operator from breakdowns, stoppages and expensive service interventions.

HYDAC diesel pre-filtration

HYDAC Diesel PreCare is a cup filter system for diesel pre-filtration available in two versions:

- **Manual water drain (BestCost Design)**
The conventional, operator-dependent solution.
- **Fully automatic discharge (plug & play) (High Tech Design)** The innovative solution for fully automatic dewatering, independent of the operator, even when operated on the suction side.

Outstanding performance data achieved by **2-stage water removal** and superb filtration characteristics through the use of synthetic media – these are the special features of these filters. Both systems are designed for use as pre-filters on the suction side and as such protect all the pumps and components in the fuel system from water and contamination.

HYDAC diesel filtration in the main flow

Efficient fuel filtration should achieve a cleanliness class of 12/9/6, even when subjected to engine vibration and load cycle changes. Machine users and OEMs also demand application-specific elements with the highest possible contamination retention capacity coupled with compact dimensions, compatibility of the elements with biofuels and environmentally friendly disposal. **HYDAC Diesel MainCare** is a cup filter system which ensures efficient and reliable filtration of diesel fuel in the main flow.

In conjunction with our customers, we develop main filter modules whose technical data meets the customer's requirements and specifications.

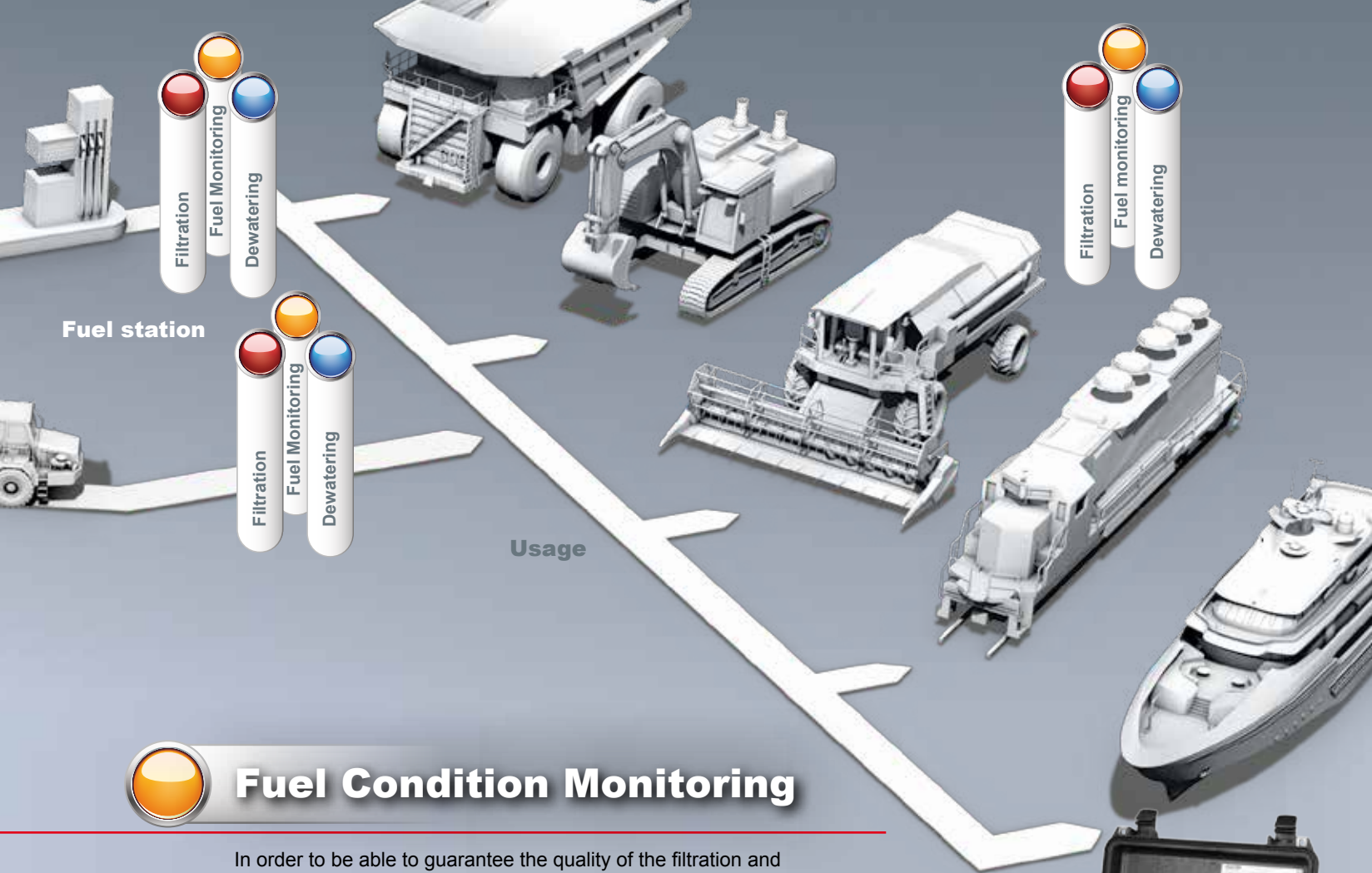

Fuel Condition Monitoring

In order to be able to guarantee the quality of the filtration and dewatering carried out over the whole process chain, both the particle contamination and the water saturation of the diesel must be checked regularly.

HYDAC measuring instruments can be used to monitor both levels. The portable **FluidControl Unit FCU 1000** is ideally suited for service work. The **CSM Economy ContaminationSensor Module** is used for stationary applications and is permanently installed in systems. From the measurements collected it is possible to check and evaluate the entire transit path of the diesel in respect of the required cleanliness and water content values, and if necessary, appropriate measures can be devised to optimise the diesel conditioning.



Dewatering units

Consumers with large tanks which are only seldom used and in which the diesel is "stored" for long periods (e.g. emergency power units) are particularly prone to heavy deposits of contamination in the form of **particle contamination** on the tank floor as well as to **increased water content** in the tank (e.g. due to condensation).

If the system is switched on, the pump typically draws off the surrounding particle contamination and the filters or system components can quickly become clogged. This usually results in system failure. The unit is therefore inoperable and high maintenance and repair costs are incurred.

Furthermore, over an extended period of time **free water** in a tank provides a breeding ground for diesel bug (microorganisms such as bacteria, algae, fungus, etc.) which also ends up blocking the filters and components. With its water separation function, the **LowViscosity Unit LVU-CD** can prevent premature and expensive disposal of the diesel (when it becomes unusable due to diesel bug).





Accumulators 30.000

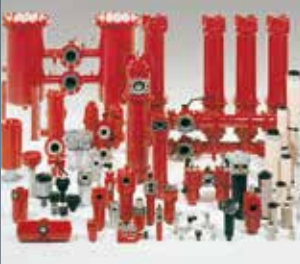

Filter Technology 70.000



Process Technology 77.000



Filter Systems 79.000



Compact Hydraulics 63.000



Accessories 61.000





Electronics 130.000



Cooling Systems 57.000

Global Presence. Local Expertise. www.hydac.com



-  HYDAC Headquarters
-  HYDAC Companies
-  HYDAC Distributors and Sales Partners

HYDAC INTERNATIONAL

**HYDAC FILTER SYSTEMS
GMBH**

Industriegebiet
66280 Sulzbach/Saar
Germany

Phone: +49 6897 509-01

Telefax: +49 6897 509-9046

E-Mail: fuel@hydac.com

www.hydac.com